



Collaborative project SCP3-GA-2013-60560

Increased Capacity 4 Rail networks through enhanced infrastructure
and optimised operations

FP7-SST-2013-RTD-1

Deliverable D5.5.3

Report from Laboratory demonstrations

Due date of deliverable : 30/09/2016

Actual submission date: 30/09/2017

Dissemination Level		
PU	Public	PU
PP	Restricted to other programme participants (including the Commission Services)	
RE	Restricted to a group specified by the consortium (including the Commission Services)	
CO	Confidential, only for members of the consortium (including the Commission Services)	

Lead contractor for this deliverable:ADIF

Document status		
Revision	Date	Description
1	2017/11/24	Final document, ADIF
Reviewed	YES	

Executive Summary

The CAPACITY4RAIL project will provide research activities in the areas of infrastructure, rolling stock, operations and monitoring techniques. These research tasks will be covered with several demonstrators that will be carried out in different environments (laboratory facilities, virtual environment and on track). These demonstrators will enable the assessment of the innovations developed in the project.

The main objectives of this WP55 – Demonstration, evaluation and assessment are:

- To carry out test-scale demonstrations on infrastructure or in laboratories or demonstrations in virtual environment of the innovations proposed in the different subprojects.
- To evaluate the technical results of the demonstrations.
- To combine these results with the scenarios evaluation to perform a global assessment of the innovations proposed in the project.
- To perform safety and risk assessment for the demonstrators according to CSM.

This document 5.5.3 will describe the selected demonstrations performed in laboratories. The test sites will be configured for each of the demonstrations according to the Test Plans

The total budget of the Demonstrators is 1.895.633 € including the costs of Coordination-Planning-Report-Assessment.

The following is the complete list of demonstrators.

SP	WP	
DEM of new prototypes of Slab Track; LAB-Rail track accelerated testing at CEDEX (1:1 scale)		
1	1.1	Demo of new prototype of Slab Track (1st prototype)
1	1.1	Demo of new prototype of Slab Track (2nd prototype)
<i>Related task</i>		
1	1.1.3	Full design of prototypes of new concepts for infrastructures
1	1.1	Lab-testing of a innovative rail section
	4.3	Real-scale tests of embedded RFID sensor tags (with SP1 - CEDEX) - Later
VHST		
1	1.2	DEM-Laboratory, Track for VHS very high speed; Rail track accelerated testing
1	1.2	Other DEM-activity/task associated: DEM-Full scale testing of an existing bridge susceptible to high vibrations
Switches and crossing		
1	1.3	Decisions tool for S&C maintenance based on track recording car information
1	1.3	Using wireless technology to S&C monitoring
1	1.3	New material for S&C crossing in service
1	1.3	Material validation data for wear map
1	1.3	Laser measurements of S&C frog nose
1	1.3	Innovative technology to remove snow in turnouts
Embebbed RFID + Innovative monitoring sensors		
4	4.3	In-lab tests of embedded RFID sensor tags
4	4.3	Real-scale tests of embedded RFID sensor tags (with SP1 - CEDEX)
4	4.3	Lab demonstration of innovative monitoring sensors
4	4.3	Real scale tests of innovative monitoring sensors
DEM of retro-fitting		
4	4.4	In-lab and on-track validation tests
DEM-Virtual reality		
5	5.5.5	DEM-Virtual reality; Impact of new technologies developed in the project.
Other DEM		
5	5.5	DEM-Coordination-Planning-Report-Assessment

Table of contents

Executive Summary	3
Table of contents	5
1. Background.....	6
2. Objectives	7
3. Laboratory Demonstrations	8
3.1. Controlling switch heating by whether prognosis	8
3.2. 3MB TEST	15
3.3. LASER Measurement trolley for switches and crossings.....	21
3.4. Material testing for wear and RCF resistance under realistic wheel-rail contact conditions	28
3.5. Tests on 1:1 scale model in CTB	37
4. Conclusions.....	43
5. References.....	44

1. Background

CAPACITY4RAIL project will deliver technological innovations that will contribute towards the achievement of 2030/2050 EU targets. The project has a cross-cutting approach and provides research in the areas of infrastructure, rolling stock, operations and monitoring techniques. As a result from the research activity, several demonstrators will be carried out in laboratory at reduced and real scale, virtual environment and on a commercial line.

The demonstrators play a crucial role in CAPACITY4RAIL as they enable the assessment of the innovations developed in the project, which will serve to identify room for improvement and will guide their further development. Moreover, the demonstrators in combination with the scenarios evaluation will enable the global assessment of the step-innovations proposed in CAPACITY4RAIL with regards to the 2030/2050 vision of the European Union, which is required to properly devise the most suitable migration path to meet EU long-term targets.

The role of WP5.5 is to coordinate and develop the demonstrations activities of CAPACITY4RAIL, in collaboration with the partners involved in it.

2. Objectives

The objectives of this deliverable are:

- To carry out test-scale demonstrations in laboratories of the innovations proposed in the different subprojects
- To evaluate the technical results of the demonstrations
- To combine this results with the scenarios evaluation to perform a global assessment of the innovations proposed in the project
- To perform safety and risk assessment for the demonstrators according to CSM

Selected demonstrations will be performed in laboratories. The test sites will be configured for each of the demonstrations according to the Test Plans.

3. Laboratory Demonstrations

3.1. CONTROLLING SWITCH HEATING BY WHETHER PROGNOSIS

The objectives of this demonstrator was to reach a TRL level of 4 and starting to evaluate the concept of using weather prognosis for switch heating.

Trafikverket has the responsibility of about 11.200 S&C. 7 500 of these are equipped with a electric heating system. The normal rail temperature is 8 degrees Celsius and the mean temperature during October – March is 0-5 degrees which gives a need of heating to about 8 degrees in about 100-160 days per year.

The project has only started and will continue even after Capacity4Rail ended. The test performed has been to evaluate the capacity to melt snow and the time to heat up a cold S&C.

Control system for switch heating

Switch heating in Sweden is gradually upgrading to a system controlled by a PLC. The PLC is activated when the rail temperature is below 8 degrees choosing the rail with lowest temperature. The heating elements are all activated with one relay so there is no separation between the sides.

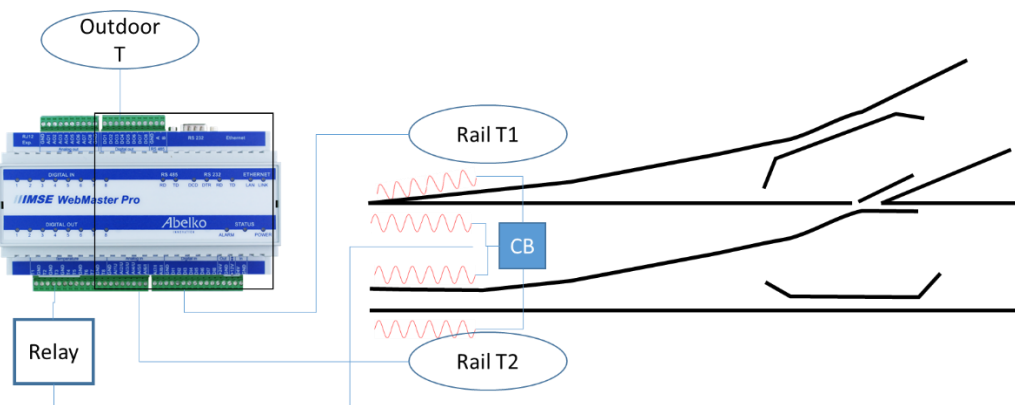

FIGURE 1. PLC USED TO CONTROL SWITCH HEATING (CB – CONNECTION BOX)

The PLC to control the switch heating is called Webmaster Pro. All Webmaster Pro stores the measurements each 5 minutes for the following parameters

- Outdoor temperature
- Rail temperature left side
- Rail temperature right side
- Indicator of snow

- Indicator if 100 % heating is activated (TURBO)
- Power consumption
- Temperature in the cabinet
- Indicator of outdoor light is on

It is possible to take out data as long as 3 years back in time for each hour. This data can be used to calculate different things, for instance

- Power consumption depending on outdoor temperature
- Check how often it snows
- Days when switch heating is necessary
- The difference between places with brush or wooden plates as snow protection

An example of this is given for Via and Kimstad. There is a difference of power consumption in the two S&C, but the reason for this has not been explored. Via and Kimstad are two stations that can be representative for Sweden as they are placed north and south of Stockholm. The yearly need for energy is 36 kWh in Via (north) and 13 kWh in Kimstad (south).

To lower the power consumption there are possibility to use an insulated snow protection, which is under test in Sweden. Another way to go is to avoid heating the S&C when there is no immediate snowfall coming.

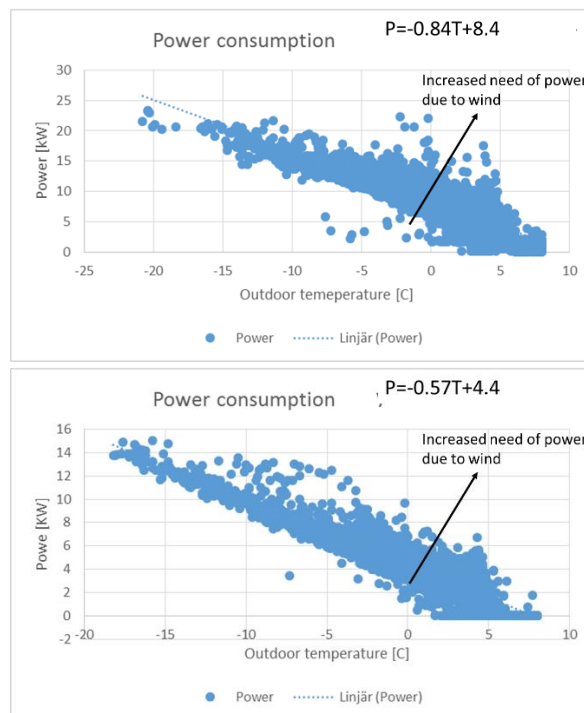

FIGURE 2. POWER CONSUMPTION FOR VIA (LEFT, 23kW) AND KIMSTAD (RIGHT, 20 kW)

Extended heating

Trafikverket is evaluating three different system for heating that can be used to heat up the front part of the switch panel. This is done by placing plates between the sleepers under the switch blade. The three companies has three different solutions with different power consumption ranging from 200 – 900 W per sleeper, giving a boost of about 300 – 1500 W/m. Already the heating elements in this part of the switch gives 700 W/m so in total 2 200 W/m is possible.

There are certain limitations with such a system that needs to be addressed. If all the elements are used at the same time larger transformer needs to be installed, which most probably not is a good solution. Instead it is better to heat up part of the elements and plates by a time sequence, which naturally will lower the total power consumption. To compensate that perhaps only 1 000 W/m is actually available the rail temperature can be increased to 20 degrees instead of normal 8 degrees. The plates are normally heated to a temperature of 60-120 degrees and all this stores energy that can be used when the snow falls.

Another issue is that the gliding chair is not properly heated by plates placed between the sleepers, therefore the conventional heating elements is still needed.

The third issue that has been discussed that using plates will give more failed components than the normal heating system gives. Though the heating plates are more reliable than heating elements, they will eventually fail. To know when the heating plates have failed is crucial to have a system that really works when it is needed. An efficient condition monitoring would be to pass the S&C 1 hour after the heating has started with a train and take photos with an infrared camera.

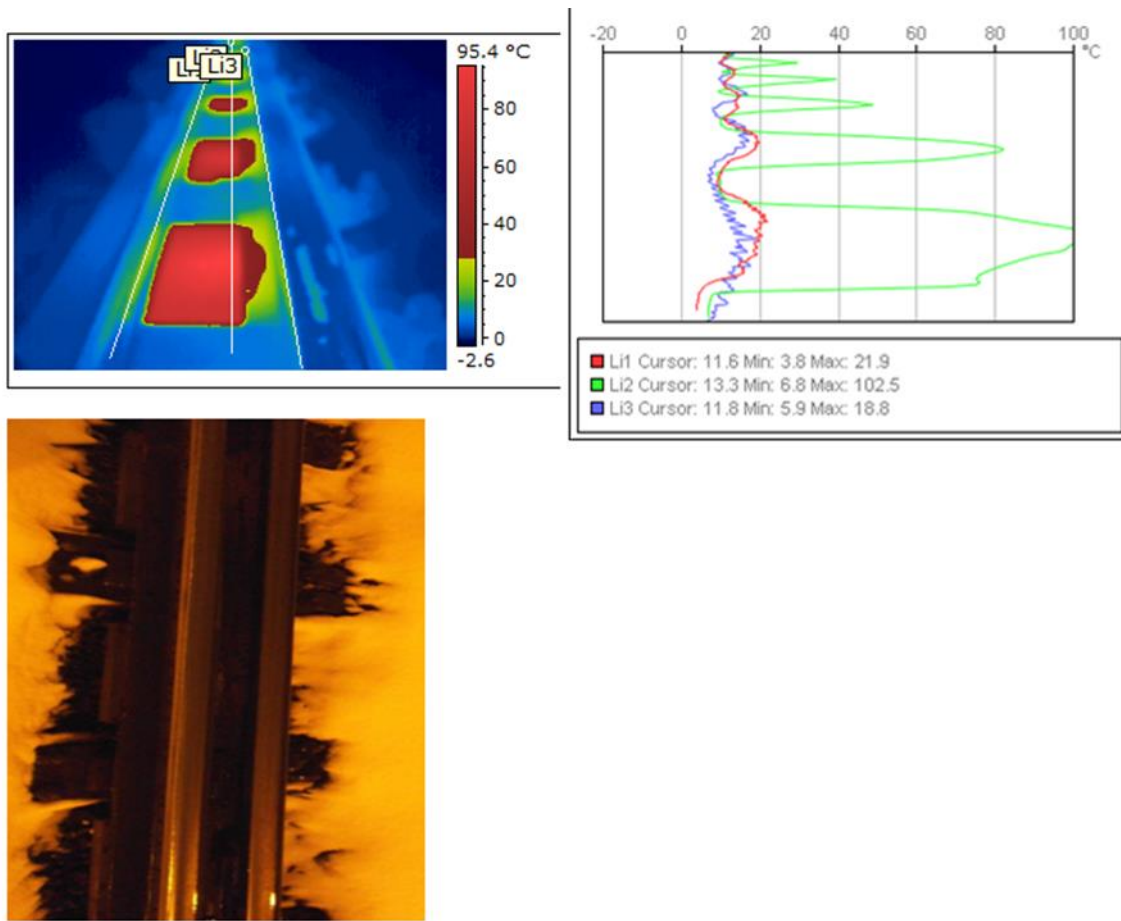

FIGURE 3. TEST WITH HEATING PLATES, PHOTO TAKEN BY ORDINARY AND INFRARED CAMERA

Test with heating plates

A first test to evaluate how fast temperature can increase was done at SAN facilities in Grästedt, Denmark in June. As it was 22-25 C outdoor it is necessary to be careful about conclusion on how fast the snow melted as the top temperature of the rail was too high. Anyway a system with heating plates and a heated rail is able to remove much snow in short time.

The first measurement was the time it takes to raise the temperature on the plates and in the rail, shown in **Erreur ! Source du renvoi introuvable.** The temperature on the plates raised 70 degrees in less than 8 minutes. The temperature on the rail head and switch blade raised by 25 degrees in 45 minutes. Assuming an out door temperature of -10 degrees or higher it is possible to switch heating 90 % of the time and just wait 1-2 hours before the snow comes and start to heat up.

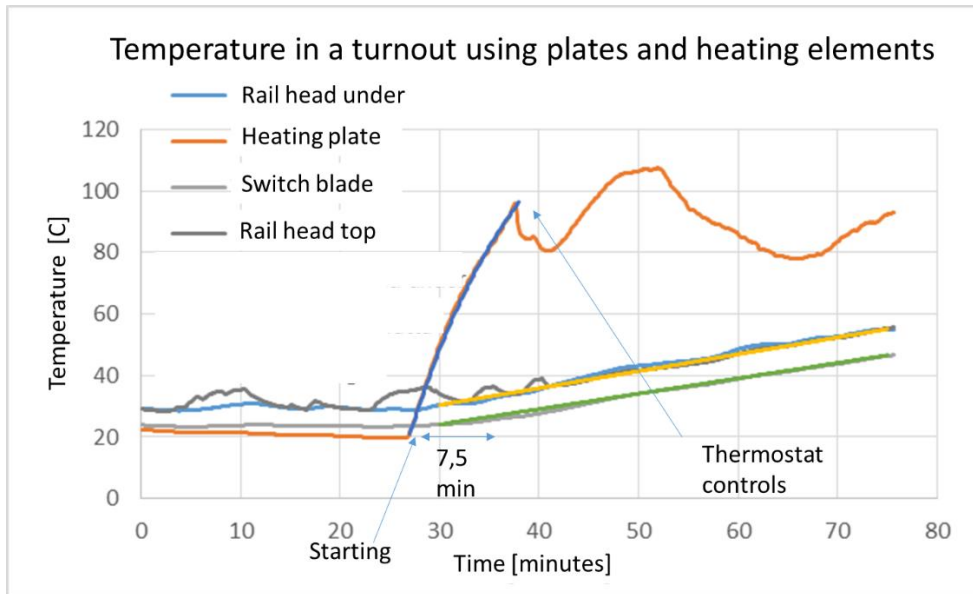

FIGURE 4. TEMPERATURE MEASUREMENT IN A SWITCH EQUIPPED WITH HEATING PLATES AND HEATING ELEMENTS

A test with putting 10 cm snow on the sliding chair was also performed, shown in **Erreur ! Source du renvoi introuvable..** The snow is melted fast as the temperature was more than 40 degrees, this time in 3 minutes. More realistic would be a temperature of 20 degrees that would need about twice the time. The interesting thing is that the temperature started to recover by the heating from the rail after about 10 minutes and after 12-13 minutes had reached the same temperature as before. The result showed that this configuration could remove over 40 cm snow/hour.

On a heating plate that is 100 degrees the snow will not even reached the plate before it is melted, see **Erreur ! Source du renvoi introuvable..** Boiling away snow is done within seconds. The heating plate as such can melt more than 80 cm snow/hour. Further test the put more snow that could fall of the trains is still to be done, but in principle the system shown in is capable to take away the amount of snow that is expected to come during the winter in Sweden including snow falling of the trains.

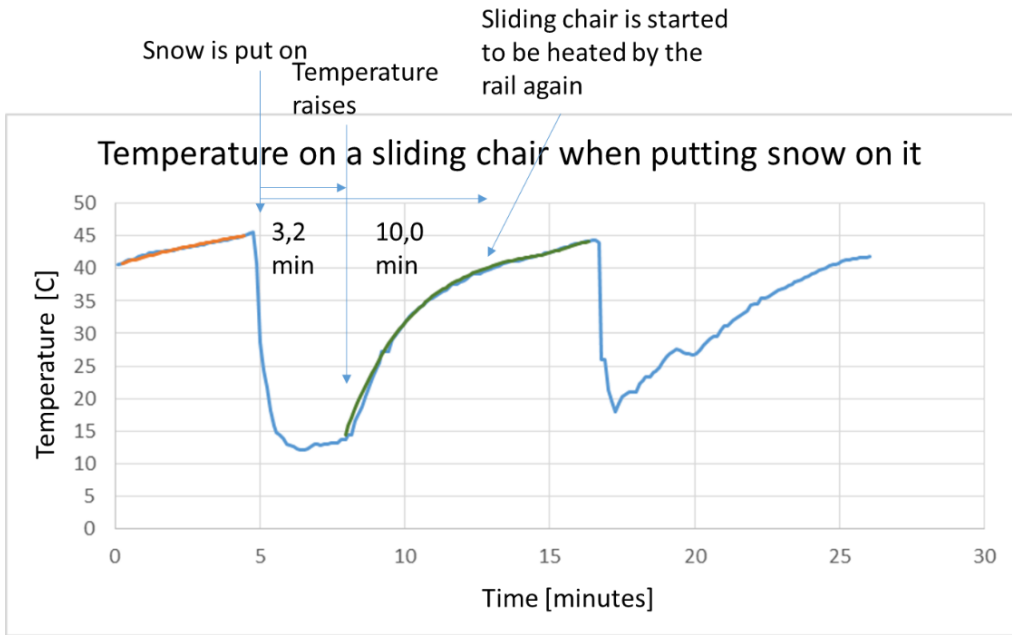

FIGURE 5. TEMPERATURE ON A SLIDING CHAIR AS SNOW IS PUT ON IT

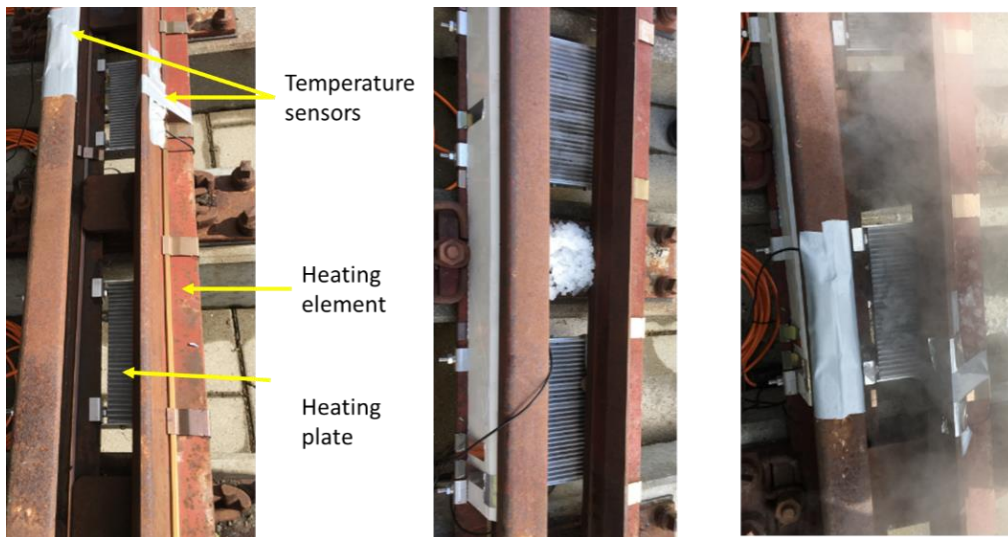

FIGURE 6. MELTING OF SNOW ON GLIDING CHAIR AND HEATING PLATE

Further work

The project has not yet come to build a system in field with the capability to use weather prognosis. The knowledge to control by weather already exist in the company Abelko which delivers WebMaster Pro, which is used for Swedish switch heating.

A first test will be performed during the winter 2017/2018.

3.2. 3MB TEST

The 3MB system is based on the concept of multiple-level modularity and strives to achieve fast and easy maintainability through the use of easily replaceable, precast components.

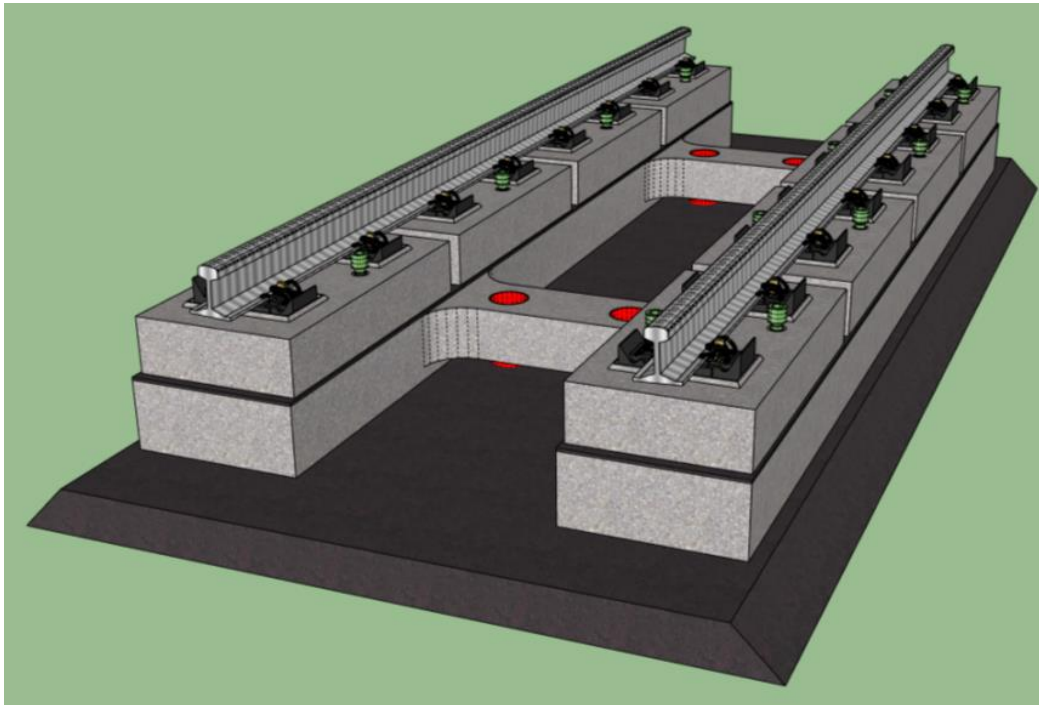

FIGURE 7. 3MB FINAL DESIGN GENERAL VIEW

This subchapter describes all the 1:1 scale model tests performed in CEDEX Track Box (CTB) on 3MB slab prototype, in the frame of Task 1.1.3 of WP 1.1. A detailed description of the tests and their results are collected in Annex IV of Deliverable 11.3

CEDEX Track Box (CTB) is a 21 m long, 5 m wide and 4 m deep facility whose main objective is to test, at 1:1 scale, complete railway track sections for passenger and freight trains, at speeds up to 450km/h. The reproduction of the effect of the approaching, passing-by and departing of a train in a test cross-section is performed by application of loads, produced by three pairs of servo-hydraulic actuators. The railway track response, in terms of displacements, velocities, accelerations and pressures, is collected from a great number of linear variable differential transformers (LVDTs), geophones, accelerometers and pressure cells that can be installed inside both the embankment and the bed layers (ballast, sub-ballast and form layer) of the track. On the other hand, the railway superstructure response is recorded with mechanical displacement transducers, laser sensors, geophones and accelerometers installed on the different track components.

DESCRIPTION OF THE EXPERIMENTAL SECTION

The cross section used in the present study is formed by the following elements: embankment, form layer, slab foundation layer, slab track, rails and fastening system, as it can be seen in Figure 8.

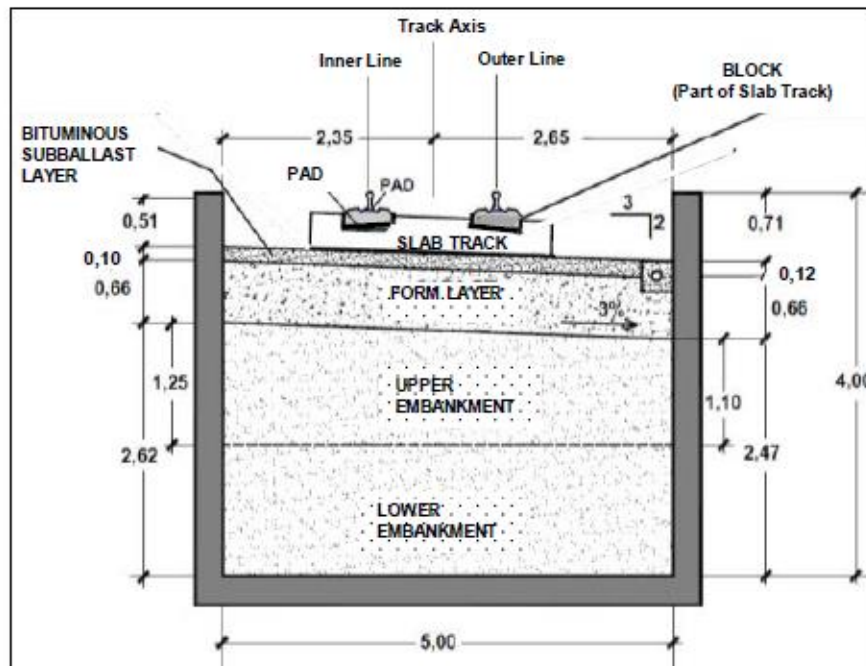

FIGURE 8. CROSS-SECTION OF 1:1 SCALE MODEL BUILT IN CTB (DIMENSIONS IN M)*

INSTRUMENTATION INSTALLED

The analysis of the dynamic test results was carried out with 54 sensors installed to cover all the main parts of the slab prototype (rail, blocks and slab). This instrumentation includes LVDT sensors, laser systems, potentiometers and accelerometers. Figure 9 shows only the position and names of the accelerometers installed.

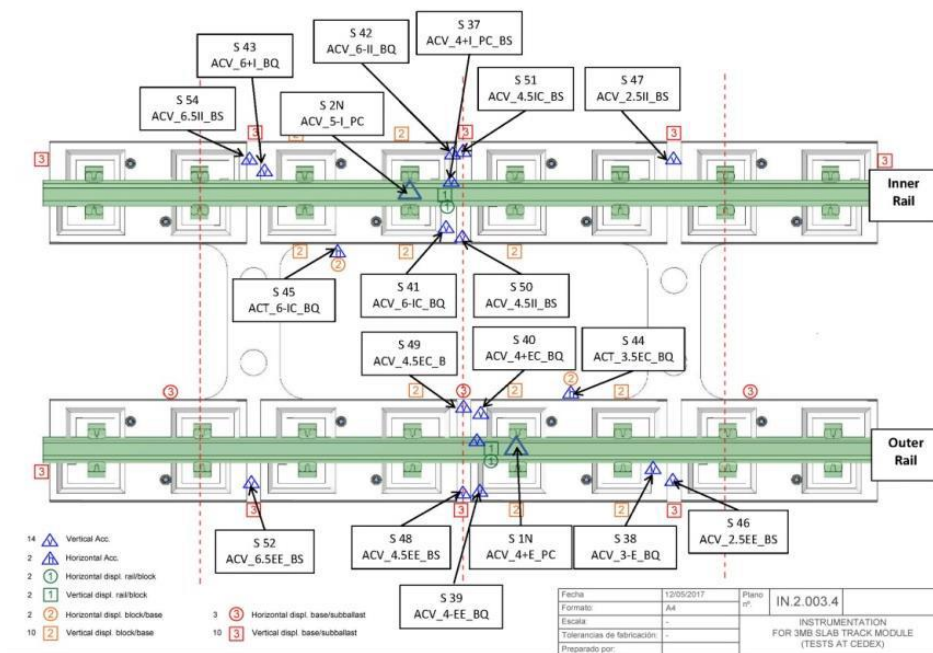

FIGURE 9. POSITION AND NAMES OF THE DISPLACEMENT SENSORS INSTALLED

On other hand, the instrumentation installed for the static tests consisted of seven vertical laser systems located along first the outer rail and then along the inner rail.

TESTS PERFORMED

The tests performed in the 3MB slab prototype were 6 static tests and 20 dynamic tests according to the following sequence:

- Static test nº 1 in the outer rail.
- Stabilization test consisted of 100.000 sinusoidal cycles to stabilize all the slab elements and to get a more uniform response.
- Plate tests on the foundation layer to check the influence of the stabilization loads in the mechanical behaviour of the prototype foundation.
- Static test nº 2 and nº 3 in the outer and inner rail, respectively, to determine the track stiffness.
- Check Static test I performed in both rails, using the instrumentation installed for the dynamic tests, to check the slab state.
- Dynamic tests simulating passenger trains travelling at speeds between 40 and 300 km/h.

- Dynamic tests simulating freight trains, with 250 and 300 kN/axle loads, travelling at speeds between 40 and 200 km/h.
- Check Static test II performed to check the slab state after the first passenger tests and all the freight tests.
- Dynamic tests simulating passenger trains travelling at speeds between 300 and 400 km/h.
- Check Static test III performed to check the slab state after the test completion.

RESULTS OBTAINED

The extensive instrumentation installed in 3MB slab prototype made it possible to record the following measurements: total track vertical displacements, slab base vertical accelerations, block vertical accelerations, rail vertical accelerations, rail – block relative vertical and horizontal displacements, block – slab base relative vertical and horizontal displacements, slab base – foundation layer relative vertical and horizontal displacements.

The results are represented, for both passenger and freight trains, as the evolution of the representative value of the mentioned parameters with the train speed. Figure 3 shows, as examples, the track vertical displacements obtained in the passenger and freight train simulation tests.

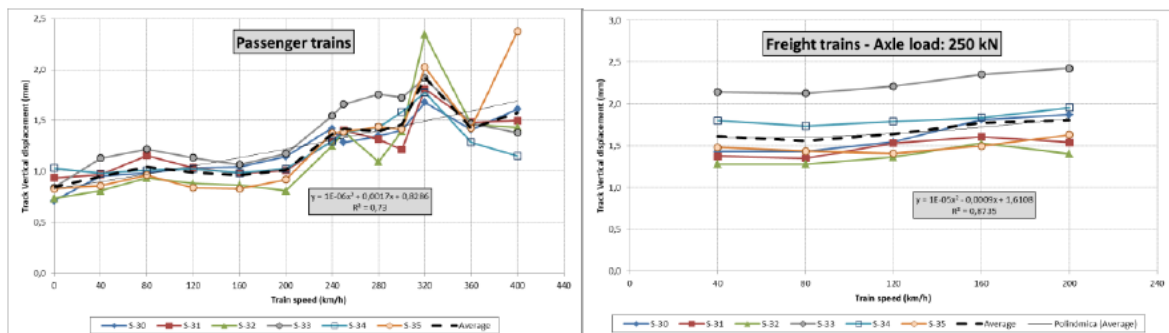

As a summary of the accelerations measured in the tests shows the trend of the test results for the rail, block and slab base vertical accelerations. It can be seen that the increase with the speed is exponential in the three elements with the following maximum values obtained for a train speed of 400 km/h: 1.4 g for the slab base, 5 g for the blocks and 7.8 g for the rail.

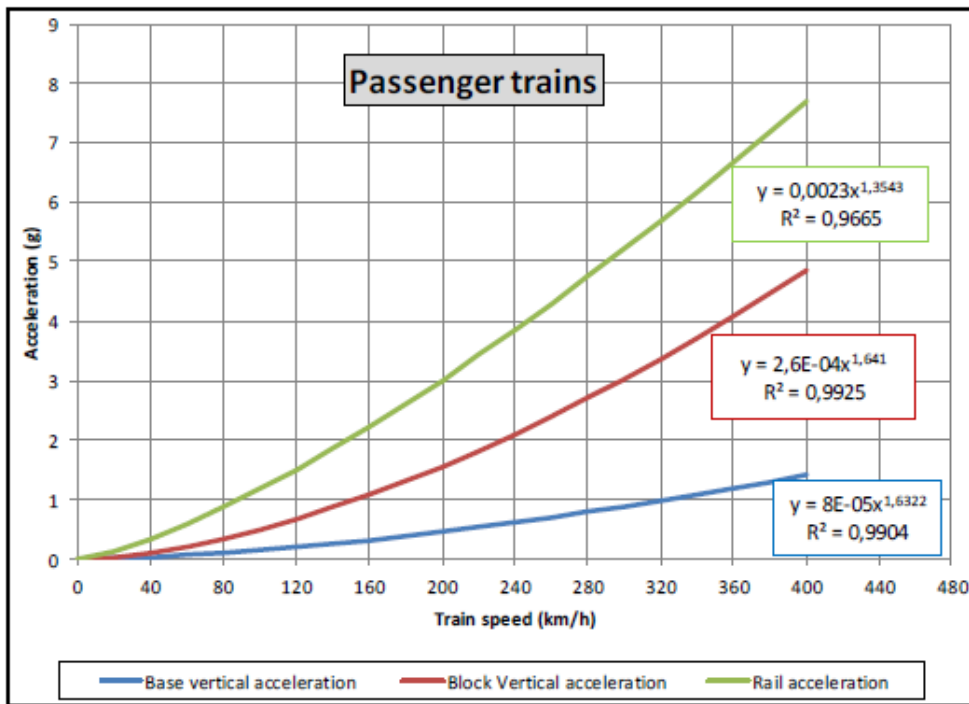

With respect to the vertical movements, it can be seen in Figure 5 the average values obtained in the different sensors that were measuring the foundation layer – slab base – block – rail relative vertical displacements, besides the total track vertical displacement during the passenger train simulations at speeds from 40 to 400 km/h. The analysis of the figure makes it possible to state that 15% of the vertical displacement is due to the concrete foundation layer placed on the bituminous layer, 30% to the elastomeric material placed between the slab base and the block and the rest (55%) due to the rail pad.

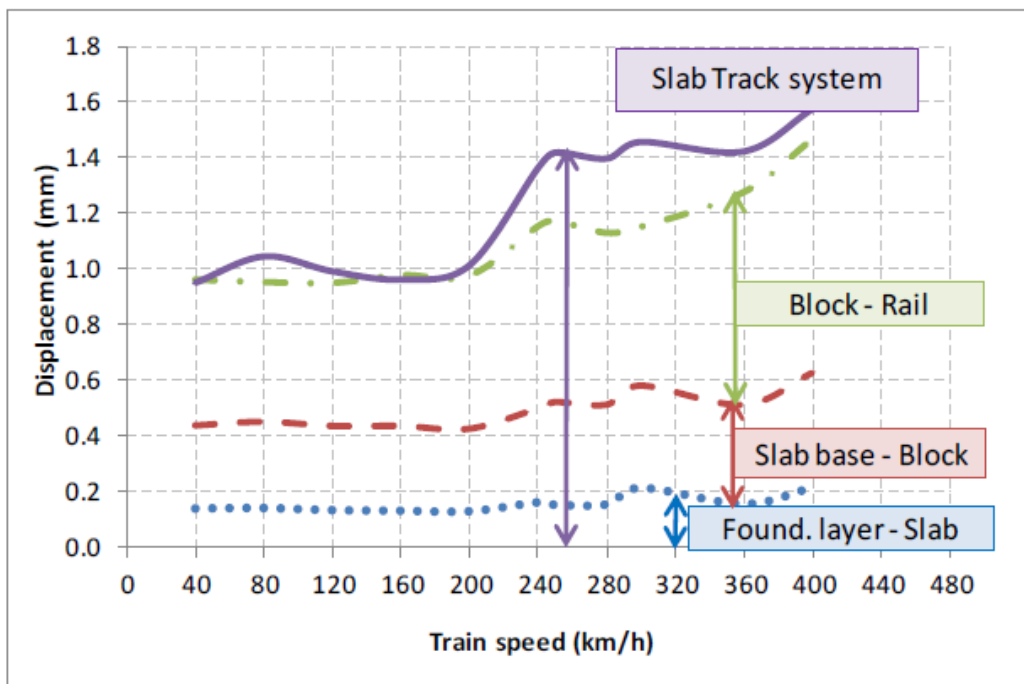

The main conclusion that can be drawn from the test result analysis is that the 3MB slab track prototype has had a good performance since, on one hand, the results obtained (in terms of displacement and accelerations) are in the range of the usual values measured in real slab tracks and, on other hand, there has not been either any structural damage or unexpected malfunction of any of the slab elements during the test performance.

TRACK TESTS

Due to unforeseen circumstances, an even though the L-TRACK demonstrator was fabricated and installed in the CEDEX track box facilities, it was not possible to perform the tests planned within the timeframe of the project.

Nevertheless, the tests shall take place in the future months, and the results shall be analysed and compiled in a report.

3.3. LASER MEASUREMENT TROLLEY FOR SWITCHES AND CROSSINGS

Measurement trolley for S&C geometry

Understanding the complex degradation mechanisms of wear, plastic deformation and fatigue damage in crossing and switches requires robust damage models supported by reliable material data as well as a mean of precisely measuring and quantifying the change in shape of the rails under traffic conditions.

Current industry practice relies on manual devices such as MiniProf and Calipri to do this. However surveying a full turnout at regular intervals implies costly operation with long track possession, often at night where quality of data can be compromised by a number of factors, most importantly the human factor.

Various semi-automated advanced solutions are available using a range of 2D or 3D laser scanner or 3D camera. The C4R consortium in WP13 agreed to investigate those solutions capable of improving the speed and reliability of track measurement with the following multiple overall objectives:

- Develop tools and methodologies that can be used for detailed investigation of S&C failures modes as well as help in the assessment of the performance of future S&C trials (new materials, new shapes and new support designs).
- Produce measurement data that can support the future research, validation and calibration of damage prediction models suitable for S&C components, in particular the data needs to be suitable for detailed wheel-rail contact modelling using simulation software such as Simpack or VI-Rail.
- Propose future use of the technology to help support maintenance decision process and increase capacity of the railway by reducing unplanned maintenance and emergency operation at S&C.

In C4R final deliverable D1.3.3 on “Innovative concepts and designs for resilient S&Cs”, the different methods of measuring S&C rails are discussed in section 3.1.1.4 and 3.2.9. Here more details are provided on the specific solution developed in WP55 by partner University of Huddersfield in the form of a trolley based laser measurement system.

Background

The University of Huddersfield in the H2020 project WRIST1 has been developing a laser based system to measure in details weld geometries, with the aim of improving the quality control and limit operational damage under traffic. The prototype research instrument has been further modified and adapted in C4R for use on switches and crossings.

While classical measurement instruments such as MiniProf and Calipri enable accurate cross sections of rail to be measured at fixed position on the track, the number of measurement required to capture

¹<http://www.wrist-project.eu/>

the rapid change of cross sectional shape in switches and crossings implies a large volume of measurements, with lengthy track possessions (even for a well-trained operator), highly repetitive manipulation of the equipment and uncertain positioning along the track. The major issue with independent cross section measurement is the inaccurate alignment of all the measured section with respect to one another. It is effectively not possible to accurately reproduce the absolute position of each measurement and the effective 3D surface that governs the wheel-rail contact conditions. All optimisation investigation reported in D1.3.3 on crossing geometry are based on having a detailed 3D geometry definition for the wheel-rail contact analysis to estimate the level of performance and damage. For such optimisation to be fully verified on track and future optimisation to be realised, this is a necessary step.

Description of the prototype

The principle of the UoH S&C trolley prototype is to mount a laser head onto a T-shaped frame so that the head is mounted on a guiding running parallel to rail of interest (see Figure and Figure for illustration). This way a reasonable length of rail may be measured in one go and with speed. If necessary the instrument can be moved along to measure consecutive lengths of rail and later recompose a complete length of interest made up of a series of measures. This way a complete cast crossing can be captured (including nose, wing and legs ends) as well as a complete set of switch-stock rails.

The laser is installed on a trolley having three resting point (T-shape), two resting on the top of the measured rail and one on the opposite rail. This way the horizontal plane of the track is known and the gauge face is used to align the trolley along the rail being measured. The laser head is mounted through a custom made bracket (allowing tilt adjustment) on a linear guide and moved at constant speed by means of an electric motor and a drive belt. The laser travels over a fixed distance of about 1.2m in about 20~30 seconds and is stopped by electronic position sensors either end of the frame. Each measurement set is therefore of a fixed length and each cross section spaced by about 0.7 mm longitudinally (around 1700 profiles). This data enables an overall 3D representation of the rail shape (i.e. weld, crossing, switches etc...) to be obtained. Note that a shorter frame was first used for weld measurement.

Similar systems are commercially available, such as GRAW scorpion, but they come at a high premium, focuses on the crossing nose only and raw data is not available for research purposes. One of the purpose of the instrument being developed here is that it can be deployed for a complete S&C survey in a manner that the data can be used for the simulations types presented in D1.3.3. At the same time it can be faster and more accurate than using standard MiniProf or Calipri system.

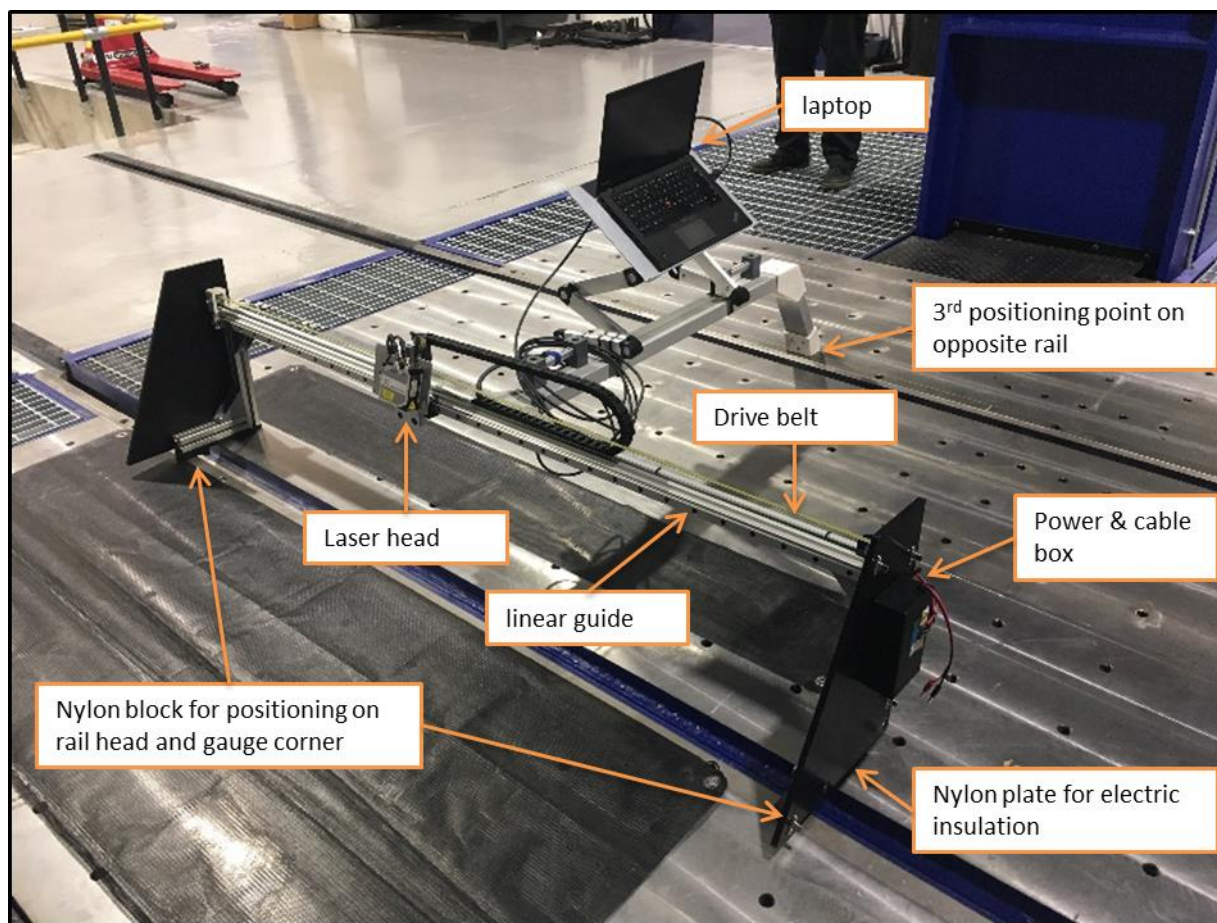

FIGURE 10. UoH S&C LASER MEASUREMENT SYSTEM MOUNTED ON T-FRAME WITH OPERATING LAPTOP

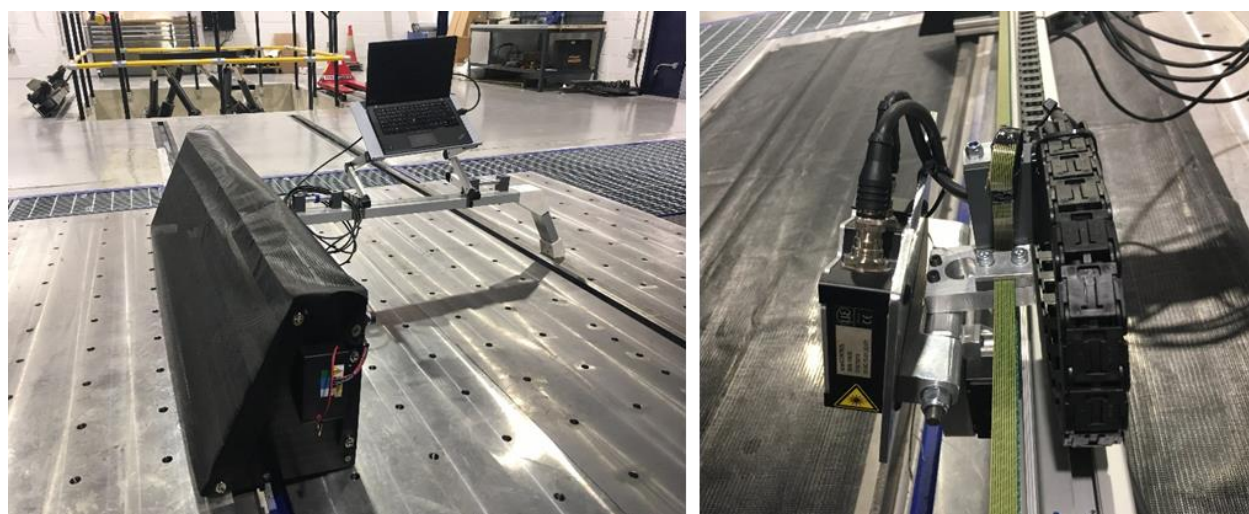

FIGURE 11. MEASUREMENT SYSTEM WITH LIGHT/RAIN PROTECTION COVER (LEFT); LASER HEAD ON LINEAR GUIDE, DRIVE BELT AND CABLE CONTROL SYSTEM (RIGHT)

Measurement carried out

The system has been tested in laboratory conditions and lately trialled on a full S&C assembly at Beeston in the UK, thanks to the support of Network Rail and Progress Rail Ltd.

In order to deal with the alignment of consecutive sets of measurement, position markers (cuboid magnets) are placed onto the rail head at each end position and become part of the measurement. During the post-processing phase, software algorithms have been developed to identify position and orientation of these markers, so that one end of a measurement can be matched and aligned to the start of the next measurement. A 3D geometry representation along a significant length (full crossing or full switch-stock assembly) is then possible.

The operation sequence of the measurement is as follow:

- Connection of the measurement trolley to a portable battery pack and to a laptop
- While the laser head gets adjusted to environmental conditions (temperature and humidity level) ~10min, cleaning and white paint spraying of the surface to be measured (switch and crossing panels) takes place
- Place the trolley at the start position of measurement ensuring good resting position on top of rail and against the gauge face
- Place the two position markers either ends of the measurement
- Check software setting for light exposure and adjust if necessary, do sample measurement and check quality
- Take 1st measurement
- Remove marker A and move the trolley to the next position above marker B
- Place marker A into new position B
- Repeat the operation...

On a crossing, the measurement is done twice, in the facing and trailing direction to capture both running surfaces for the wheel rail contact.

During the software post-treatment, the following steps are carried out:

- Smooth each profile to remove undesired measurement noise
- Detect and eliminate anomalies (generally due to high or low reflection or missing) and check sufficient data is available to capture all possible running surface for the wheel-rail contact analysis
- Average profiles based on user selected desired profile spacing (while original spacing is less than 1mm, the necessary data can be of the order of 5mm or more).



Clean the measuring surface and spray with white paint before measurement



Place marker A at the beginning of the measuring location and marker B at the end of the measuring location

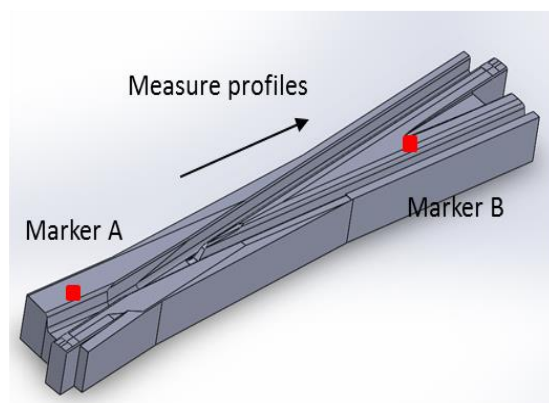

FIGURE 12. SWITCH SET OF POINTS MEASURED AT BEESTON WITH PAINTED SURFACE (UPPER-LEFT); DETAILS OF A MARKER PLACED ON PAINTED CROSSING WING SURFACE (UPPER-RIGHT); TROLLEY MEASUREMENT AND OPERATION ON CROSSING PANEL ASSEMBLY (BOTTOM-LEFT); ILLUSTRATION OF PLACEMENT OF MARKERS ON CROSSING (BOTTOM-RIGHT)

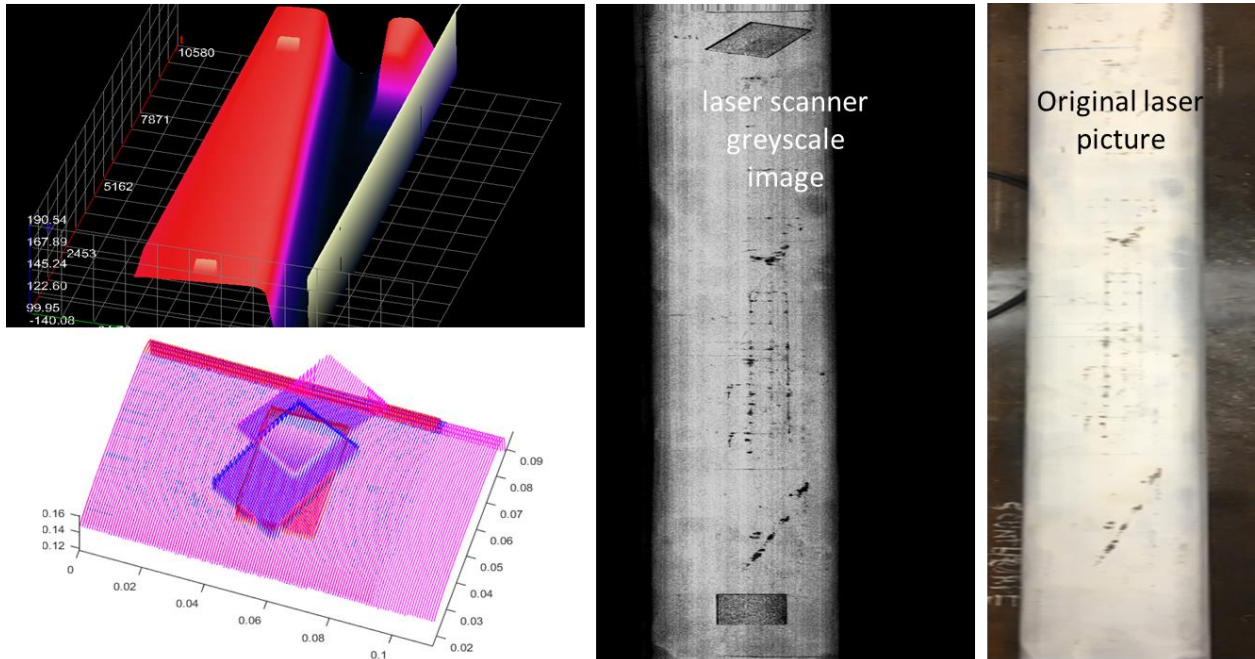

FIGURE 13. RAW VIDEO CAPTION FROM THE LASER HEAD (FAR RIGHT) AND TREATED GREYSCALE VIDEO (MIDDLE RIGHT); EXTRACTED 3D PROFILES SHOWING MARKERS (UPPER-LEFT) AND ALIGNMENT PROCESS OF TWO CONSECUTIVE MEASUREMENTS BASED ON MARKERS POSITION (LOWER-LEFT)

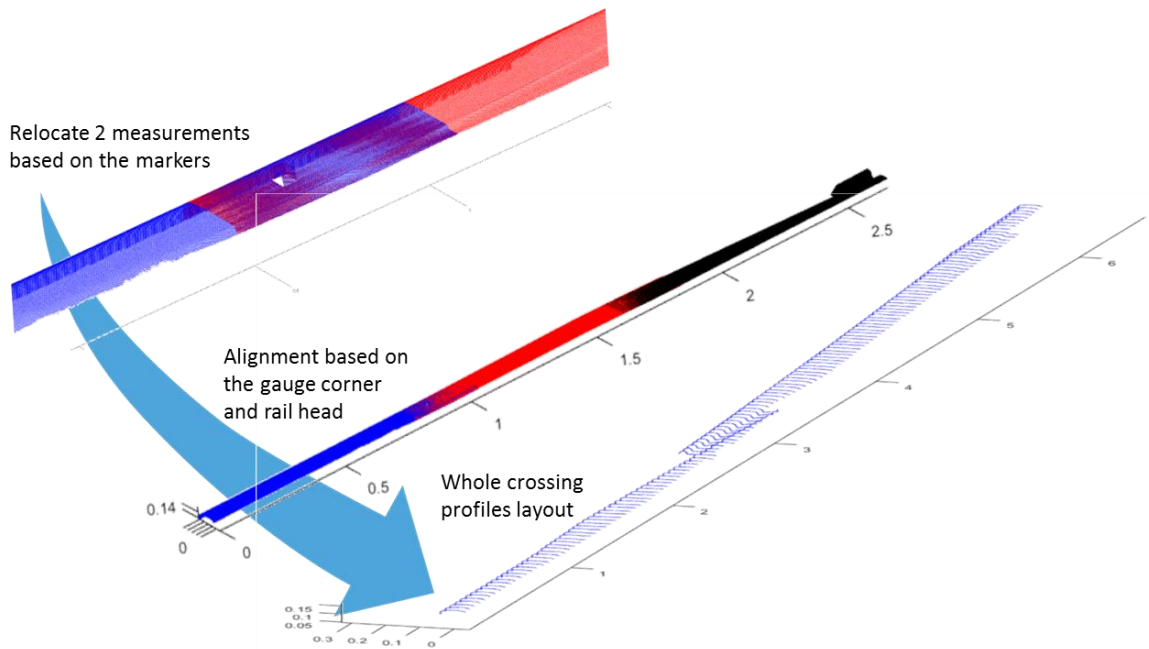

FIGURE 14. ASSEMBLY OF INDIVIDUAL MEASUREMENT INTO ONE COMPLETE SET (EXAMPLE OF A 6M LENGTH CAST CROSSING)

State of development and Further work [YB]

At present the prototype has been developed to a point where it is practically ready to be used on live track. Although a site visit was planned with Network Rail in August 2017, it was eventually not possible to attend the site due to the heavy program of maintenance taking place during that night possession.

The key issues that were encountered and addressed during the development work are:

- Calibration of the system to ensure repeatability of measurement – this is still pending
- Robust realignment of the individual measurement – partially dependent on calibration above
- Handling and transportation of the equipment – T-frame split in two to fit in a car
- Full electrical insulation of the system for track use to prevent short circuit
- Light weighting – currently best handled by two people to ease operation
- Varying ambient/reflecting light affecting quality of measurement – meshed material cover, use of paint, measurement during night possession.

The next steps of development envisaged are:

- Fully calibrate the rig using precision measurements tools (available from colleagues at UoH)
If necessary, move away from square aluminium assembled frame and commission on purpose made welded aluminium frame design
- Improve electrical insulation (better designed nylon pads and plates)
- Improve light weighting (weight optimisation of end nylon plates)
- Develop software robustness for multiple measurement assembly

Recommendation and potential Impact

The development of the innovation directly or indirectly addresses the research challenges identified and published on Network Rail website for track and lineside S&C as follow:

[indirect] How can alternative materials or coatings be utilised to enhance the performance of crossings? Improvements should prolong life, reduce whole-life cost and reliance on maintenance. Weld repair processes should be considered for any alternatives.

[indirect] Optimise crossing (wing and nose) profiles using a combination of analytical and practical techniques. Consideration of manufacturing methods should be given.

[direct] How can improved inspection methods (both automated and manual) help predictive maintenance whilst furthering our understanding of precursors to wear/damage?

[indirect] What improvements can be made to monitoring and maintenance of crossings including RCM? How can we use existing data to improve understanding of failures?

[indirect] Enhanced vehicle dynamics modelling will help drive improvements to crossing design and understanding of failure modes.

This innovation prototype has the potential to impact on the above research goals in such a way:

- The research prototype will be capable of evaluating the performance of a range of crossing design geometry in track operated under different conditions and subject to different degradation mechanisms. This can be catalogued and used as input data to simulation techniques; c.f. Multibody (MBS) simulation used in D1.3.3; to improve the understanding of key drivers for each damage mechanism.
- Evaluate the performance improvement attained from remedial actions such as welding on nose/wing, as well as help with quality control definition.
- Support further research in material and help understand their performance on track. Contribute to the development and verification of wear and rolling contact fatigue analysis models linked to MBS simulation.
- Lead the way to develop industrial solutions for digital measurement and quality control of S&C manufacture, installation and repair.

3.4. MATERIAL TESTING FOR WEAR AND RCF RESISTANCE UNDER REALISTIC WHEEL-RAIL CONTACT CONDITIONS

Research work carried out by Chalmers and the University of Huddersfield in C4R WP13 on the optimisation of switches and crossings, has shown that the correct choice of material for use in key S&C component (switch & stock rails, wing and nose in crossings) is fundamental in increasing the longevity and reliability of the S&C asset and keeping operational costs down.

Current prediction models for damage mechanisms such as wear and RCF, based on results from vehicle-track dynamic and wheel-rail contact analysis, use parameters obtained from traditional twin disc testing on small scale 1 line contact rollers, which have limited resemblance with the contact conditions predicted in wheel-rail S&C contact. This means that currently accepted prediction methods are still limited in their applications to S&C and full value of state of the art simulation capabilities are not yet realised. This Document explains how UoH C4R demonstration funding was used to increase the scope and outputs from a national research project funded by EPSRC (EP/M023303/1) by developing enhanced wheel-rail contact material testing capabilities. This enables the direct comparison of the performance in a wide range of steels, including those used in S&C, under rolling contact conditions representative of those observed in a range of curving conditions and approaching those observed in S&C.

Introduction

Optimum selection of materials is a key requirement to achieve reductions in whole-life costs of the railway system through increased asset life and reduced maintenance while realising performance improvements through increased service availability and reliability. Selecting the optimum materials for wheels and rails is a complex task with many conflicting requirements, including: a range of failure mechanisms, operating conditions and the associated financial implications.

Recent research has focused on investigating changes to vehicle-track characteristics (e.g. wheel profile design, lower vehicle primary yaw stiffness, increases in cant deficiency) to reduce the forces and damage generated at the wheel-rail interface, whereas less effort has been spent on increasing the resistance of the materials to the imposed forces. Historically the industry has relied upon testing of properties such as hardness and tensile strength and to a limited extent comparative assessment of wear resistance under simplified contact conditions. However, there is a knowledge gap in the understanding of the influence of microstructural constituents of various steel types on their ability to counter effectively other damage mechanisms such as rolling contact fatigue (RCF), plastic deformation and corrugation.

Recent development of ‘High Performance’ (HP) rail steels have shown, through laboratory and on-track testing, that improvements in the resistance to both wear and RCF can be achieved through judicious choice of alloying elements to alter the microstructural characteristic of the steel (e.g. HP335 rail, developed in the UK by British Steel (formerly Tata Steel) and successfully deployed by NR, and carbide-free bainitic steels deployed in Eurotunnel >1000 MGT no grinding). However, the understanding of the reasons for the success of such steels requires further fundamental research.

Research Aims

This research aimed to establish a comprehensive scientific understanding of the metallurgical characteristics of rail steels to enable scientifically-informed choices, taking into account both the specific requirements arising from the peculiarities of railway wheel-rail contact and the economic trade-offs at a system-wide level. The results of such research will help establish the design rules to engineer steel microstructures that provide a step change in the resistance to key degradation mechanisms with greater predictability of the deterioration rates.

Phase 1 of the EPSRC research project was led by the University of Huddersfield in collaboration with University of Cambridge, University of Leeds and Cranfield University. The industrial project stakeholders and members of the steering group include: British Steel, Network Rail and RSSB.

In addition, the funding from C4R was used to help enhance the scope and capabilities of the testing so that it can be extended to contact conditions and steels relevant for S&C applications.

Summary of results obtained with the phase 1 of EPSRC and C4R projects

The aim of the first phase of the research project was to understand the response of various microstructural constituents of steels to the loads imposed on them during wheel-rail contact, identify

the characteristics of the steel which are important to resist the key degradation mechanisms and develop a methodology for optimising steel grade choices at a granular level based on the outputs from a cost-benefit analysis.

To achieve this aim, Phase 1 of the research included the following key objectives:

- To develop techniques to enable better characterisation of wheel-rail forces and damage susceptibility of routes with a range of track and operating conditions.
- To develop a methodology for testing of steels that better reflects the expected in-service performance and to use it to investigate the performance of a matrix of steel microstructures under closely controlled and comparative conditions.
- To develop techniques for the quantitative assessment of microstructural deformation to accommodate the strains induced from realistic wheel-rail contact conditions and thereby identify microstructural and compositional characteristics that can be converted to design rules for the next generation of degradation resistant rail steels.
- To define a methodology to optimise the selection of steel grades taking into account key degradation mechanisms, vehicle-track characteristics and operational conditions, and economic value (assessment of whole life costs and relevant potential benefits within a cost-benefit analysis framework)
- Carry out research to understand the economic (incentives-based) barriers to implementation and make recommendations on changes to the structure of incentives to facilitate implementation.

The research programme is the first to undertake a methodical and controlled study of the reaction of different steel microstructures to the contact conditions encountered during wheel-rail contact, and then to establish a methodology for selecting the appropriate steel choice at a granular level for different parts of a route, taking account of whole life costs and benefits for the entire route.

Summary of Key Achievements

The key achievements from Phase 1 of the research project can be summarised as follows:

Recognising that different segments of a route on any network have different magnitudes of susceptibility to the key degradation mechanisms – a methodology for identifying the damage susceptibility of these segments has been developed, as summarised in Figure 15 below.

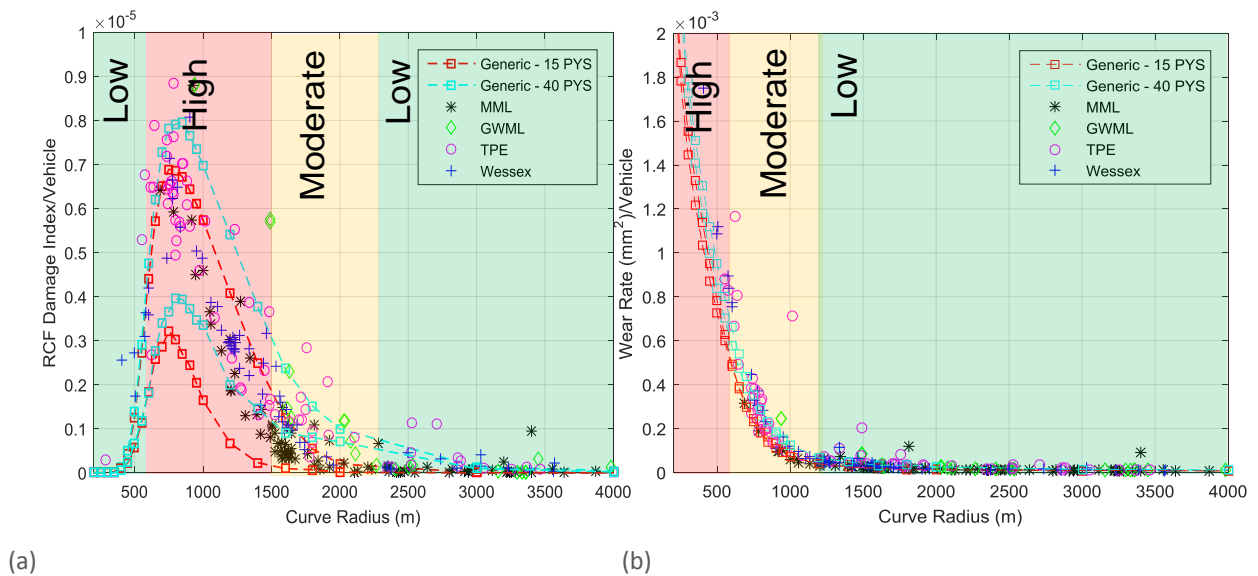

FIGURE 15. RAIL DAMAGE SUSCEPTIBILITY – (A) ROLLING CONTACT FATIGUE AND (B) WEAR

Based on the outputs from the wheel-rail contact modelling; a laboratory twin-disc facility has been developed that generates wheel-rail contact conditions that have a closer resemblance to the actual damaging loading conditions seen on track.

This rig includes larger diameter (300 mm) wheel-rail discs than typically seen on most twin disc testing machines with controllable slippage and angle of attack between the discs.

Whole or segmented discs can be used (for concurrent testing of multiple samples), which can either be obtained from actual rail samples (rolled or heat-treated) or, for experimental steel grades, from laboratory rolled plates.

Samples have been acquired for the full range of steel grades included in the current GB/European (EN13674-1: 2011) standards along with some novel steels produced by rail manufacturers.

The project has also utilised the twin disc facility at British Steel to test rail samples under controlled conditions. This facility utilises much smaller diameter discs, but has the advantage of a significant amount of historic data on the RCF and wear resistance of a wide range of steels.

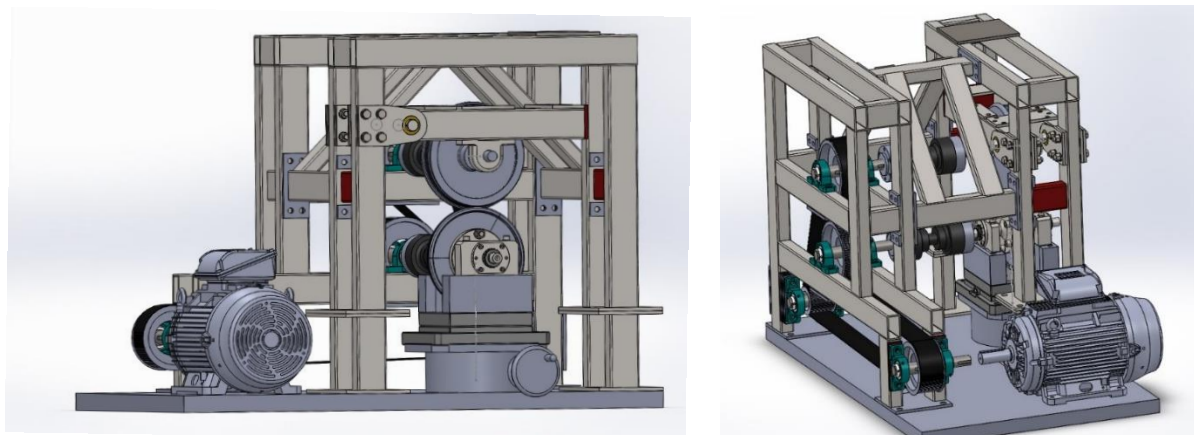

FIGURE 16. TWIN DISC TESTING FACILITY 3D DRAWINGS

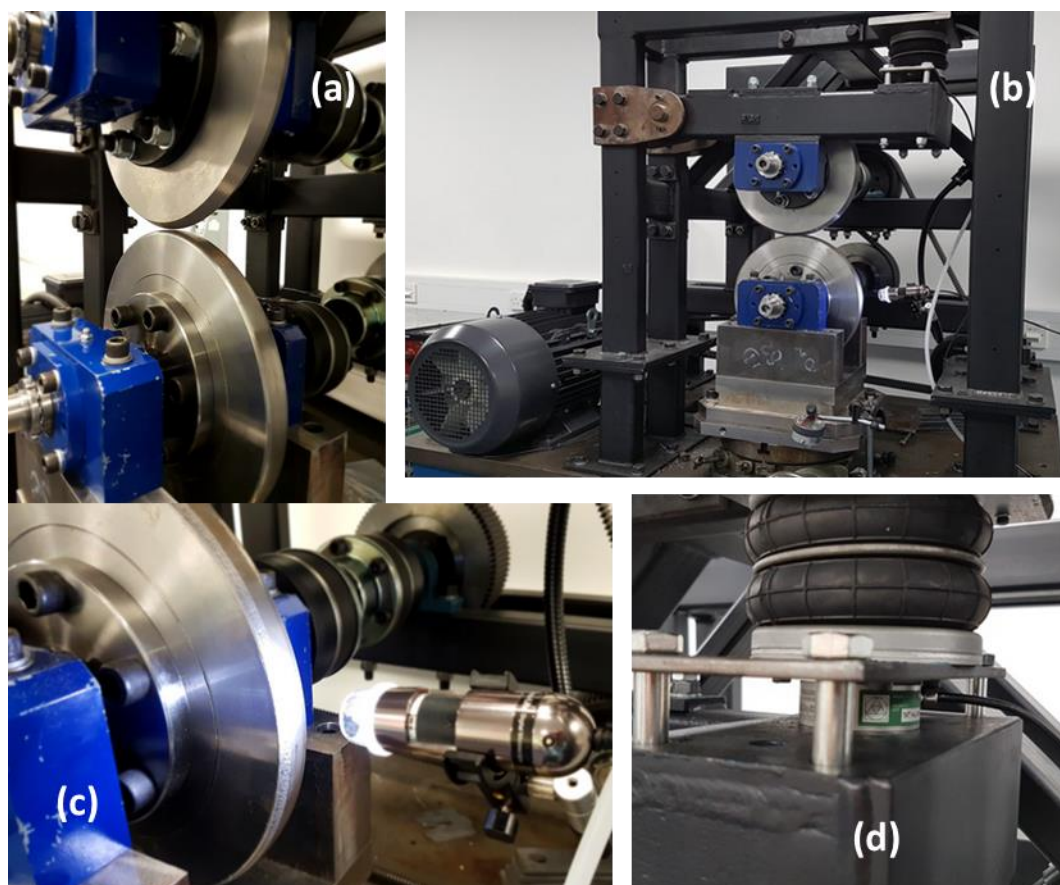

FIGURE 17. TWIN DISC TESTING FACILITY BUILT SHOWING FRAME AND DRIVE MOTOR (B), WHEEL-TOP AND RAIL-BOTTOM ROLLER (A), RAIL TEST ROLLER WITH DIGITAL MICROSCOPE (C) AND PRESSURED AIR LOAD ACTUATOR AND LOAD CELL (D).

Detailed metallurgical examination combined with neural network analysis of test results from selected laboratory twin disc test samples has drawn some key conclusions for the contribution of compositional and microstructural parameters on the life to initiation of RCF:

- Hardness of hypereutectoid steels achieved through accelerated cooling has a more significant influence on their resistance to RCF, although alloying with appropriate elements can enhance this attribute further.
- Fragmentation of the pearlitic cementite lamellae and consequently their dissolution is a key microstructural feature differentiating the RCF resistance of steels – those alloyed with silicon (as is the case for HP335) better resist the dissolution of cementite and thereby impart improved resistance to RCF.
- Vanadium alloyed steels, such as HP335, displayed less plastic deformation and shallower depths of cementite fragmentation than those without vanadium at similar levels hardness.
- Alloying with manganese is considered beneficial for resistance to RCF, but alloying with chromium has a negative influence.
- Finer interlamellar spacing of pearlite is considered to have a second level of influence on the resistance to RCF through its effect on the depth of cementite dissolution.
- The microstructural assessment and neural network analysis have not been able to support the perceived hypothesis that increased volume fraction of cementite provides greater resistance to RCF. Further data are required to examine the influence of this parameter on rail steel degradation.
- Further data from controlled tests of a matrix of compositions to assess the resistance to wear, RCF, and plastic deformation are required to better define the design rules for rail steels.

In collaboration with Network Rail; a detailed cost-benefit analysis approach has been developed to assess the impact of optimum rail steel grade selection on whole routes. This approach includes a life cycle cost assessment using the industry-standard VTISM tool in addition to identifying the additional benefits (e.g. alignment of grinding activities, reduction in temporary speed restrictions etc.) which are difficult to quantify. The key achievements in this area include:

Development of a methodology for incorporating optimum rail steel grade selection in the VTISM tool and calculation of potential cost savings for a number of routes with a range of track conditions.

Identification of additional benefits, which are difficult to quantify economically, from use of high performance rail steels.

A significant interview programme has been completed to review incentives and innovation.

New econometric modelling approaches and evidence developed on the relationship between cost and reliability and on marginal costs to support track access charging.

Recommendations

As highlighted by the achievements generated from Phase 1 of the project summarised above; the project team has made good progress in the area with a few key breakthroughs in the understanding of the influence of alloying elements and hardness on degradation of rail steel microstructures.

Figure 18 summarises the RCF resistance of a range of pearlitic rail steels. It can be seen that the RCF resistance of rails steels defined in the EN standard show a linear dependency with hardness, whereas the HP rails show a greater resistance than the EN grades at equivalent hardness.

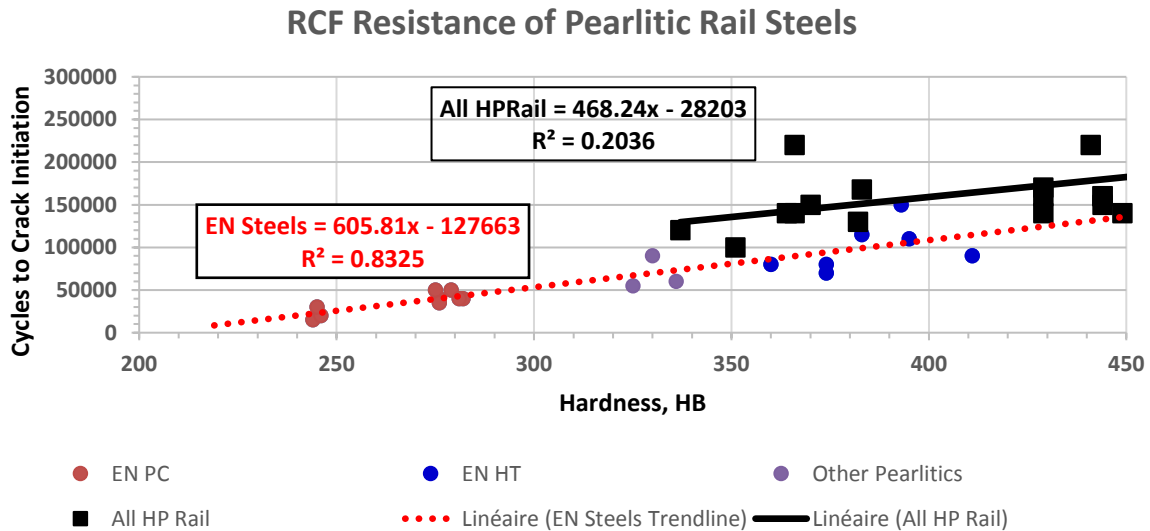

FIGURE 18: RCF RESISTANCE OF PEARLITIC RAIL STEELS

To better understand these trends and to the optimise the composition of HP rail steels; support for further work is required to undertake controlled testing and microstructural assessment to cover the matrix of compositions to establish the design rules for rail steels and thereby establish whether the performance of the current premium grade could be improved. The proposed assessment programme will also provide a singularly unquedatabase for the rail industry both in the UK and Internationally.

Proposal for further work in Phase 2

The University of Huddersfield is currently seeking further funding to complete the research beyond C4R and EPSRC (EP/M023303/1) in a phase 2 programme and fully exploit the potential of the test rig developed. A key objective of Phase 2 of the research project is to establish the key compositional and microstructural attributes of steels deployed in the three key components of the track infrastructure: plain line rail, switch blade, and crossing nose. In addition, research will be focussed on the study of degradation around welds between rail lengths caused by the changes in microstructure and properties across the heat affected zones (HAZ). The wheel-rail contact conditions experienced by these components have been thoroughly assessed for a variety of vehicle types and track infrastructure characteristics and a range of these contact conditions are to be reproduced in the twin disc rig at the Institute of Railway Research. The output of the proposed research will be the rate of degradation of a range of steels as a function of track, vehicle, and traffic characteristics.

Justification for Phase 2

The metallurgical assessments undertaken at University of Cambridge during Phase 1 of the project were completed on a limited number of available samples, tested for RCF resistance on the small-scale twin disc machine located at British Steel. Despite the limitation, the work has identified that fragmentation of the pearlitic cementite lamellae and consequently their dissolution during local plastic deformation, is a key microstructural feature differentiating the RCF resistance of steels. Steels alloyed with silicon (as is the case for HP335) resist better the dissolution of cementite, and thereby impart improved resistance to RCF. Vanadium alloyed steels, such as HP335, displayed less plastic deformation and shallower depths of cementite fragmentation than those without vanadium at similar levels hardness.

These aspects require further verification using samples tested under contact conditions closer to those seen on in-service rails. Assessment of the depth of cementite fragmentation in both hypo and hypereutectoid steel rails taken out of track also needs to be undertaken.

A full matrix of steels has been identified and include compositions relevant to steel grades used in the manufacture of Switches and Crossings (S&C) and thereby applying the findings of the current research for the optimisation of material selection for S&C also. Acquisition of samples of the matrix of steel grades has been initiated. This will complement the detailed modelling work that has been undertaken to predict the variation in wheel-rail forces and damage susceptibility of different S&C components during EU / Shift2Rail projects (e.g. Capacity4Rail, In2Rail and In2Track).

The influence of decarburisation on the early initiation of RCF cracks with little subsequent propagation in HP335 steel needs to be examined since there is no objective measure of decarburisation within the quality analysis procedure for the manufacture of this grade.

Although the positive influence of rail steel hardness on its resistance to both wear and RCF has been supported by the limited number of samples examined in the current research, it is necessary to

establish whether the superior resistance to RCF of HP335 steel could be further extended through appropriate accelerated cooling to increase its hardness.

The metallurgical findings of current research also suggested that refinement of interlamellar spacing per se played a secondary role in the resistance to RCF. However, as accelerated cooling increases hardness and reduces interlamellar spacing at the same time, there is a need to examine and better understand the interdependencies amongst these parameters. The link with the volume fraction of cementite at the wheel-rail interface and its influence on the resistance to both wear and RCF also needs to be established.

The influence of microstructure and properties on wear resistance (both under rolling/sliding contact with the tread of the wheel and the abrasive contact that exist in the contact between the side of the rail and the flange of the wheel) was not investigated in the recently concluded project. The matrix of steel grades and test conditions proposed during Phase 2 will examine this aspect and will permit the optimisation of steel selection for switch blades or rails in tight radius curves. It will also provide the technical driver for the development of composite rails manufactured using additive manufacturing techniques.

Crossing noses and rail ends at insulated block joints experience high dynamic loading which leads to degradation through plastic deformation. The matrix of tests proposed has also been designed to examine the influence of steel properties on this degradation mechanism.

Furthermore, the proposed testing will allow the impact of changes in rail steel composition on the performance of the wheel steel to be quantified. This will help to confirm the findings from previous in this area.

Conclusion and impact of the Research

The work initiated at Huddersfield with the contribution from EC funding in C4R will have a direct impact on the continued research and development in Shift2Rail provided this research is further supported. In particular, the 'In2Track' Work Package 3 aims to significantly improve the performance of the track structure. This relates to costs, robustness and performance. The outputs from the research proposed here will contribute to all these areas as detailed below.

Task 3.1 – Status, prioritised areas of improvement and key influencing parameters

The research will define the performance of current available steel compositions under identical loading conditions and potential for future improvements.

Task 3.2 – Enhanced prediction and design of track

The research will assess the potential for enhanced materials for a range of track assets, through cost and robustness evaluations. The models developed through the research can be used to assess the most reliable material to tackle the key deterioration mechanisms. Procedures to test the performance

of steel compositions under representative loading conditions will also be defined to support the development of the next generation of steels.

Task 3.3 – Enhanced track maintenance and operation

The research outputs will help to understand the impact of changes to steel composition on the current maintenance and inspection regime for both S&C and plain line track. This might include the definition of alternative intervention levels for new steel compositions. They will support the investigation of the influence of optimal steel selection on the maintainability of track, which will be quantified through LCC techniques.

3.5. TESTS ON 1:1 SCALE MODEL IN CTB

OBJECTIVES

This chapter collects the works performed by CEDEX relative to the demonstrator defined in the Sub-Task 1.2.2. “Verification by full scale models” of WP 1.2. The scope of this demonstrator is to define the possible modifications in the design and in the maintenance operations of the current high speed lines (HSL) to be able to hold very high speed trains (VHST) when travelling at speeds up to 400 km/h.

Before performing any test, it was decided that CEDEX provides data from previous tests performed in CTB on ballasted tracks to other C4R partners for them to calibrate and validate their numerical models. Chapter 3 collects all the information that was provided in February 2015.

As a starting point, the performance of an existing track system in operation will be subjected to an increase in the operation speed and then the system will be improved by adding elements to withstand the expected effects. The results will make it possible to create a matrix of data, useful to understand the performance of railways at such high speeds.

All components of the track bed and platform of the model will be fully monitored to record the variations in track stiffness, speed and accelerations. The short term and long term effects induced in the mechanical performance of the model by the passage of trains simulated under VHST conditions will be recorded.

All these tests should have been performed in CEDEX Track Box (CTB). However, unfortunately during some maintenance works carried out in CTB, a problem in the hydraulic system was discovered. To solve the problem repair works were performed between September 2016 and January 2017, just the period previously scheduled for the performance of VHST tests, so the tests could not be performed. However, it is worth noting that during the time devoted to the repair works, CEDEX built the 1:1 scale model of a ballast track to perform the VHST tests, as described below.

RESULTS OF PREVIOUS TESTS

The data of previous tests sent to calibrate the numerical models were obtained in a 1:1 scale model of a ballasted track with granular subballast tested in CTB some years ago. The model was subjected to the pass-by of 1 M axle loads of a passenger train travelling at 300 km/h.

In Appendix 8.1 of Deliverable 12.1, there is a description of the model tested, the instrumentation installed and the results obtained.

DESCRIPTION OF THE MODEL TO BE TESTED

The structural section of CEDEX Track Box is 4 m deep and it is formed by the following elements, listed from bottom to top: Embankment, Form layer, Subballast layer, Ballast and Sleeper, rails and fastening system [1 and 2]. Figure 18 shows the schematic structural section used in the present study.

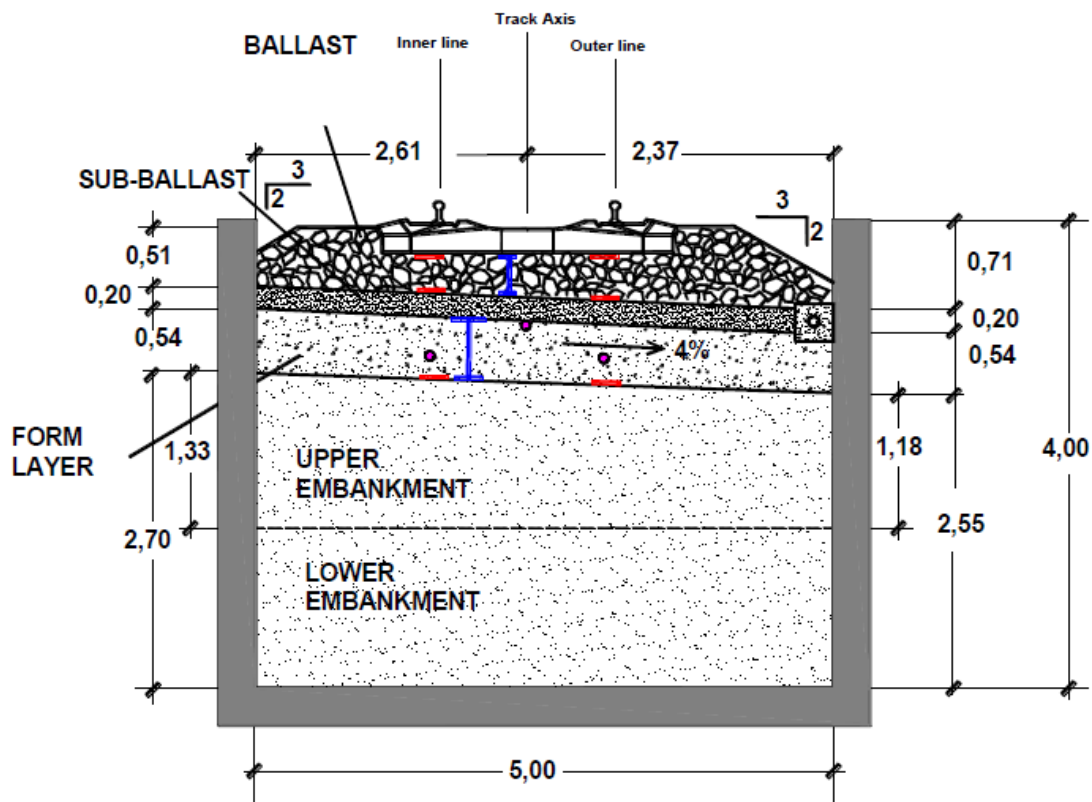

FIGURE 19. CROSS SECTION USED IN THE PRESENT STUDY

The 1:1 scale model constructed is provided with: a rail gage of 1.435 m; a ballast thickness of 0.35 m under the inner rail and 0.40 m below the outside rail; a granular subballast layer of 0.20 m thickness with an inclination of 4% towards the outside and a form layer with the same inclination and a thickness close to 0.55 m. Ballast was compacted in two layers: 0.20 m thick each one under the outer rail; and 0.20 m thick the lower one and 0.15 m thick the upper one under the inner rail.



FIGURE 20. BALLASTED TRACK PREPARED FOR THE VHST TESTS

The sensors to be deployed in CTB testing zone will have been aimed to the measurement of the absolute and relative displacements of the track components in the static tests and to the evaluation of the amplitude of displacements, velocities and accelerations induced in those components by the pass-by of trains at speeds up to 400 km/h.

Two different systems will be used:

- External system: constituted by a set of around 40 sensors providing absolute and relative displacements of rails, rail-sleeper pads and sleepers in the static tests and the amplitude of displacements, velocities and accelerations of those elements under the pass-by of simulated trains in the quasi-static tests. It will consist on the following sensors:

Laser systems.
Rail-pad resistivemeters.
Rail 2 Hz geophones.
Sleeper 1 Hz geophones.
Rail ± 50 -g accelerometers.
Sleeper ± 10 -g accelerometers.

- Internal system: made up of 40 sensors placed in the track bed layers (ballast, and subballast), form layer and embankment to play the same roles that the external sensors in the track superstructure elements. Furthermore, some ballast particles instrumented with accelerometers inside will be placed in some points of the railway track to measure the accelerations in the ballast layer.

DESCRIPTION OF TESTS

The set of tests to be performed at CEDEX Track Box (CTB) began with the construction of an existing VHS track with similar characteristics to the one already in operation in the 'Madrid – Barcelona' line. The type of train to simulate in the actuators will be the Siemens S-103 and Talgo S-102, as they are the trains whose pass-by have been recorded in the in-situ test campaigns described in Appendix 8.2. of Deliverable 12.1

The tests to be performed in this stage are the following:

Test A: 300 km/h and 106 axles to study short and long term behaviour
Test B: 320 km/h and 105 axles to study short term behaviour
Test C: 360 km/h and 105 axles to study short term behaviour
Test D: 400 km/h and 106 axles to study short and long term behaviour

After this, some new components will be implemented in the experimental track and the improved track will be tested in the same conditions as previous. Two setups are planned to test.

Test 2: Vossloh System with nominal stiffness 60 kN/mm (the secant will be 18-68 kN according to EN standard).

Test 3: Vossloh System with nominal stiffness 60 kN/mm (the secant will be 18-68 kN according to EN standard) and USP with 0.3 N/mm³ bedding modulus.

- Accelerations, with $\pm 50\text{-g}$ accelerometers and $\pm 10\text{-g}$ accelerometers

The measurements will be made at:

- Rail: with 2 Hz geophones and $\pm 50\text{-g}$ accelerometers.
- Rail pad: with rail-pad potentiometers.
- Sleeper: with 1 Hz geophones and $\pm 10\text{-g}$ accelerometers.

4. Conclusions

Controlling switch heating by whether prognosis.

There are certain limitations with such a system that needs to be addressed. If all the elements are used at the same time larger transformer needs to be installed, which most probably not is a good solution. Instead it is better to heat up part of the elements and plates by a time sequence, which naturally will lower the total power consumption. To compensate that perhaps only 1 000 W/m is actually available the rail temperature can be increased to 20 degrees instead of normal 8 degrees. The plates are normally heated to a temperature of 60-120 degrees and all this stores energy that can be used when the snow falls.

Another issue is that the gliding chair is not properly heated by plates placed between the sleepers, therefore the conventional heating elements is still needed.

The third issue that has been discussed that using plates will give more failed components than the normal heating system gives. Though the heating plates are more reliable than heating elements, they will eventually fail. To know when the heating plates have failed is crucial to have a system that really works when it is needed.

3MB slab track

The main conclusion that can be drawn from the test result analysis is that **the 3MB slab track** prototype has had a good performance since, on one hand, the results obtained (in terms of displacement and accelerations) are in the range of the usual values measured in real slab tracks and, on other hand, there has not been either any structural damage or unexpected malfunction of any of the slab elements during the test performance.

Material testing for wear and RCF resistance under realistic wheel-rail contact conditions

The work initiated at Huddersfield with the contribution from EC funding in C4R will have a direct impact on the continued research and development in Shift2Rail provided this research is further supported. In particular, the 'In2Track' Work Package 3 aims to significantly improve the performance of the track structure. This relates to costs, robustness and performance. The outputs from the research proposed here will contribute to all these areas.

5. References

- Einstein Z., Zweistein D., Dreistein V., Vierstein F. & St. Pierre E. : “Spatial integration in the temporal cortex.” - *Res. Proc. neurophysiol Fanatic Soc.* 1, 45-52, 1974.
- Chou O. & Lai A.: “Note on the tomatonic inhibition in the singing gorilla.” *Acta laryngol.* 8, 41-42, 1927.
- Perec G.: “Experimental demonstration of the tomatotropic organization in the Soprano (Cantatrix sopranica L.)”
- CEDEX Track Box as an experimental tool to test railway tracks at 1:1 scale. J. Estaire, F. Pardo de Santayana, V. Cuéllar. In Proceedings of the 19th International Conference on Soil Mechanics and Geotechnical Engineering, Seoul 2017.
- Testing railway tracks at 1:1 scale at CEDEX Track Box. José Estaire, Vicente Cuéllar & María Santana. International Congress on High-Speed Rail. Ciudad Real (Spain), 4-6 October 2017
- Instrumentation techniques for studying the horizontal behaviour of high-speed railways. J. Moreno Robles; I. Crespo-Chacón; J. L. García-de-la-Oliva. *Procedia Engineering - Advances in Transportation Geotechnics III.* 143, pp. 870 - 879. Elsevier, 2016.
- On the use of geophones in the low-frequency regime to study rail vibrations. I. Crespo-Chacón; J. L. García-de-la-Oliva; E. Santiago-Recuerda. *Procedia Engineering - Advances in Transportation Geotechnics III.* 143, pp. 782 - 794. Elsevier, 2016.
- Maciel, R. & Ferreira, P., 2016. Optimization algorithm applied to VHS track design towards enhanced track dynamic performance and reduced settlement, 11th World Congress on Railway Research -WCRR 2016. Milan.
- Ferreira, P. & López-Pita, A., 2015. Numerical modelling of high speed train/track system for the reduction of vibration levels and maintenance needs of railway tracks. *Construction and Building Materials*, pp. Volume 79, pages 14–21.
- Ferreira, P. & Maciel, R., 2014. Inverse problems applied to the optimization of numerical model validation of railway track dynamic behavior. Lisbon, 4th International Conference on Engineering Optimization - EngOpt2014, Lisbon, 8-11th September, 2014.
- Ferreira, P. & López-Pita, A., 2013. Numerical modeling of high-speed train/track system to assess track vibrations and settlement prediction. *Journal of Transportation Engineering*, Volume 139, pp. 330-337.
- Ferreira, P., 2010. Modelling and prediction of the dynamic behaviour of railway infrastructures at very high speeds, PhD Thesis, Instituto Superior Técnico, Lisbon.